

Circuit Breaker for Equipment thermal, THT terminals for PCB mounting, 1 pole

new



Description

- Thermal circuit breaker
- 1-pole
- Reset type
- Cycling trip-free release
- THT connectors

Standards

- IEC 60934
- UL 1077
- CSA C22.2 235
- GB 17701

Characteristics

- Designed for standard and medical applications
- Power supplies
- Uninterruptible power supply
- Power tools
- Industrial appliances
- HVAC
- Household appliances

Weblinks

[pdf-datasheet](#), [html-datasheet](#), [General Product Information](#), [Approvals](#), [CE declaration of conformity](#), [RoHS](#), [CHINA-RoHS](#), [e-Shop](#), [SCHURTER-Stock-Check](#), [Distributor-Stock-Check](#), [Detailed request for product](#)

Technical Data

Rated Voltage AC	240 V, 50 / 60 Hz
Rated Voltage DC	48 / 32 V, see approvals
Rated current	3-15 A, see approbations
Conditional short circuit capacity	IEC: Inc, PC1, AC 240V: 2kA UL / CSA: SC, AC 240 V DC 48 / 32 V: 2 kA, C1
Degree of protection front side	IP 40
Endurance minimum	IEC: 200% I _r , cos φ 0.6: min. 50 switching cycles
Endurance typical	3-8 A: 150% I _r , cos φ 0.9: 2500 switching cycles 10-15 A: 150% I _r , cos φ 0.9: 6000 switching cycles
Dielectric Strength	1500 VAC
Insulation resistance	500 VDC > 1000 MΩ

Ambient temperature	3 A: -5 °C to 60 °C
	4 A: -5°C to 50 °C
	5-15 A: -5 °C to 60 °C
Soldering Methods	Wave
Solderability	245 °C / 3sec acc. to IEC 60068-2-20 / Test Ta, method 1
Resistance to Soldering Heat	260 °C / 10sec acc. to IEC 60068-2-20 / Test Tb, method 1A
Weight	approx. 12.5 g

Dimension

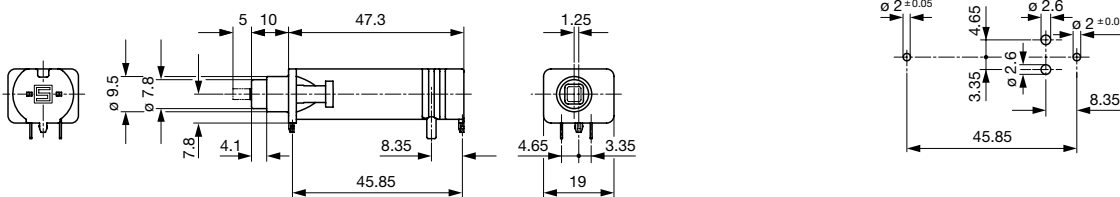



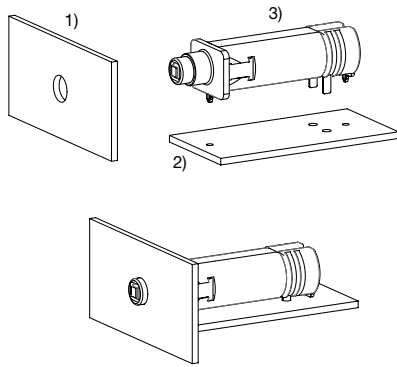

Drilling diagram

Assembly Instructions



- 1) Front panel
- 2) PCB
- 3) T9-818

Approvals

Approval		Rated current	Rated voltage AC	Rated voltage DC
 US	UL 1077	3 - 12 A 14 - 15 A	240 V 240 V	48 V 32 V
 US	CSA 22.2 235	3 - 12 A 14 - 15 A	240 V 240 V	48 V 32 V
	IEC 60934	3 - 12 A 14 - 15 A	240 V 240 V	48 V 32 V
	GB 17701	3 - 12 A 14 - 15 A	240 V 240 V	48 V 32 V

Typical internal resistance

Rated Current [A]	Internal Resistance [mΩ]
3	80.0
4	26.3
5	24.1
6	19.0
7	18.0
8	14.8
10	13.0
12	12.7
14	9.7
15	8.0

Time-Current-Curves

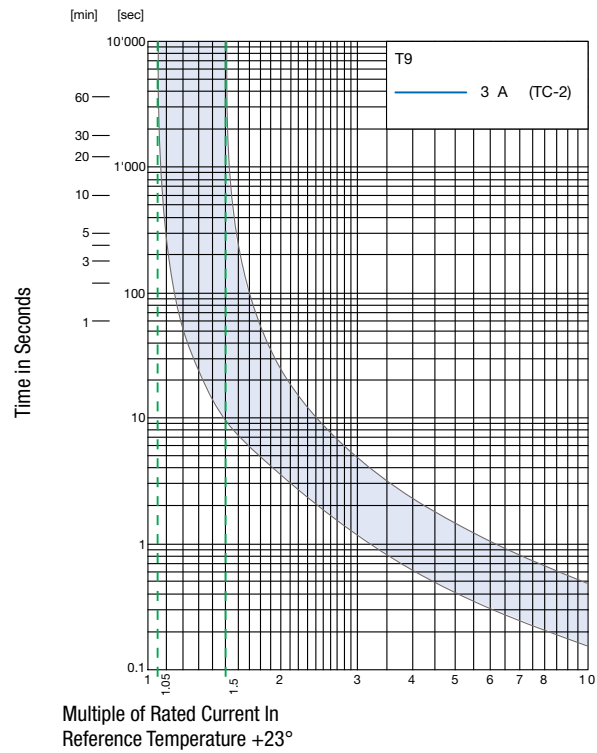
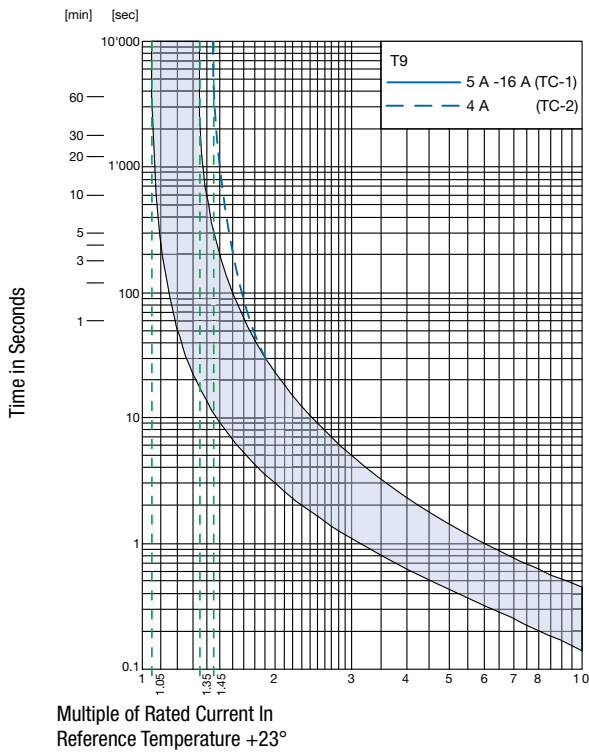

Effect of ambient temperature

The units are calibrated for an ambient temperature of +23°C. To determine the rated current for a lower or higher ambient temperature, use a correction factor (typical value) from the table below:

Ambient temperature [°C]	Correction factor
-5	0,85
+10	0,95
+23	1,00
+40	1,08
+60	1,21

Example: Rated current = 10 A; Environmental temperature = 60 °C; --> Correction factor = 1.21; Resulting current = 12.1 A --> Fount to next higher rated current: 13 A

Variants

Mounting	Rated current	Order Number
Solder THT	3.0 A	4404.0096
Solder THT	4.0 A	4404.0097
Solder THT	5.0 A	4404.0098
Solder THT	6.0 A	4404.0099
Solder THT	7.0 A	4404.0100
Solder THT	8.0 A	4404.0101
Solder THT	10.0 A	4404.0102
Solder THT	12.0 A	4404.0103
Solder THT	14.0 A	4404.0104
Solder THT	15.0 A	4404.0105

Most Popular.

Availability for all products can be searched real-time:<http://www.schurter.com/en/Stock-Check/Stock-Check-SCHURTER>

Packaging Unit 100 Pcs
