

Multilayer Ceramic Capacitors (4 Array Type)

Series: **ECJR, ECJT**



■ Features

- 4 miniature capacitors built in 0805 and 1206 case size
- Improved placement time on mounting machines
- Low self-inductance and excellent frequency characteristics
- RoHS compliant

■ Recommended Applications

- Input/Output circuit for a computer motherboards
 - Serial port
 - Video port
 - Parallel port

■ Handling Precautions

See Page 49 to 54

■ Packaging Specifications

See Page 46, 47, 58

■ Explanation of Part Numbers

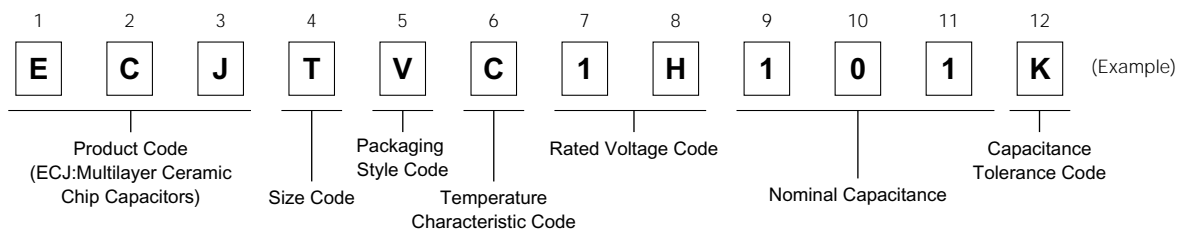

■ Construction

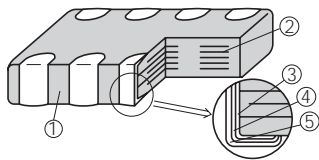

No	Name
①	Ceramic dielectric
②	Internal electrode
③	Substrate electrode
④	Intermediate electrode
⑤	External electrode

Schematic

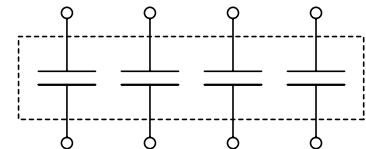

■ Dimensions in mm (not to scale)

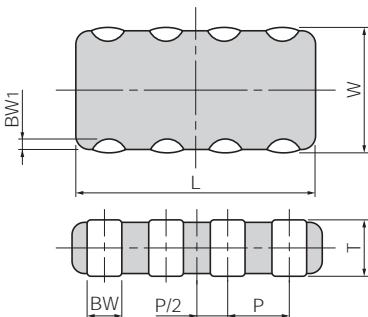

Size Code	Size (EIA)	L	W	T	BW	BW ₁	P
T	0805	2.00±0.15	1.25±0.15	0.85±0.10	0.25±0.10	0.2 ^{+0.3} _{-0.1}	0.5±0.1
R	1206	3.2±0.2	1.6±0.2	0.85±0.10	0.40±0.15	0.2 ^{+0.3} _{-0.1}	0.80±0.1

■ Packaging Styles and Standard Packaging Quantity

Quantity: pcs./reel

Packaging Style Code	Packaging Styles		Size	Quantity	
				0805	1206
V	φ180 reel	Paper taping (Pitch : 4 mm)		4,000	

Temperature Characteristics

● Class 1

Temperature Characteristic Code	Temperature Characteristics	Temp. Coeff. (ppm/°C)	Rate of Capacitance change at each Temp. (%)			
			-25 °C		85 °C	
			max.	min.	max.	min.
C	CH	0 ± 60	0.49	-0.27	0.39	-0.39

Temperature coefficient: calculated between 20 °C to 85 °C

● Class 2

Temperature Characteristic Code	Temperature Characteristics	Capacitance Change	Measurement Temperature Range	Reference Temperature
B	B	±10 %	-25 to 85 °C	20 °C
	X7R	±15 %	-55 to 125 °C	25 °C
	X5R	±15 %	-55 to 85 °C	25 °C
F	F	+30, -80 %	-25 to 85 °C	20 °C
	Y5V	+22, -82 %	-30 to 85 °C	25 °C

For applicable "temperature characteristics", see the lists of standard products on page 31 to 32.

Rated Voltage

Code	1H	1E	1C	1A	0J
Rated Voltage	DC 50 V	DC 25 V	DC 16 V	DC 10 V	DC 6.3 V

Nominal Capacitance

Ex.	100	101	104	105
Nominal Capacitance	10 pF	100 pF	100,000 pF (0.1 μF)	1,000,000 pF (1.0 μF)

Capacitance tolerance

Class	Temperature Characteristics		Tolerance Code	Capacitance Tolerance	
1	CH	Capacitance range	C=10 pF	F	±1 pF
			C>10 pF	K	±10 %
2	B, X7R, X5R		M	±20 %	
	F, Y5V		Z	+80, -20 %	

Specifications and Test Method

Item	Specifications		Test Method	
	Class 1	Class 2		
Operating Temperature Range	Temp. Char. CH: -55 to 125 °C	Temp. Char. B, X7R: -55 to 125 °C X5R: -55 to 85 °C F, Y5V: -30 to 85 °C	—	
Dielectric Withstanding Voltage	No dielectric breakdown and/or damage		Test voltage: Class 1: Rated voltage × 300 % Class 2: Rated voltage × 250 % Duration: 1 to 5 s Charge/discharge current: 50 mA max.	
Insulation Resistance (IR)	10000 MΩ or 500/C (MΩ) Whichever is less Note: 100/C (MΩ) min. for DC 10 V max. C: Nominal Cap. in μF		Measuring voltage: Rated voltage Duration: 60±5 s Charge/discharge current: 50 mA max.	
Capacitance	Within the specified tolerance		Measuring temperature: 20±2 °C	
Q Factor or Dissipation Factor (tan δ)	Q: C < 30 pF: Q>400+20 C 30 pF<C<1000 pF: Q>1000 C: Nominal Cap. in pF	tanδ: Temp. Char. B, X7R: 0.025 max. X5R: 0.075 max. F, Y5V: 0.125 max. Please see the technical specifications for details.	Class 1	
			Measuring frequency	1 MHz ± 10 %
			Measuring voltage	0.5 to 5 Vrms
			Class 2	Preconditioning: The capacitors shall be kept in temperature of 150 +0/-10 ± for 1 hour and subject to standard condition* 48±4 hours before initial measurement.
			Measuring frequency	1 kHz ± 10 %
			Measuring voltage	1.0±0.2 Vrms

* Standard condition: Temperature 15 to 35 °C, Relative humidity 45 to 75 %.
For further information, see the technical specifications.

Design and specifications are each subject to change without notice. Ask factory for the current technical specifications before purchase and/or use.
Should a safety concern arise regarding this product, please be sure to contact us immediately.

■ Standard Products for EIA "0805", Taped Version

● Class 1

- ◆ Temperature Characteristic Code: C (Temperature Characteristics: CH)

Rated voltage		DC 50 V		
Capacitance (pF)	Capacitance Tolerance	Part No.	Dim. T (mm)	Temp. Char.
10	±1 pF (F)	ECJTVC1H100F	0.85	○
22	±10 % (K)	ECJTVC1H220K	0.85	○
47		ECJTVC1H470K	0.85	○
100		ECJTVC1H101K	0.85	○
220		ECJTVC1H221K	0.85	○

Standard packaging quantity of Packaging Style Code *V* (T = 0.85 mm): 4,000 pcs./reel
Avoid flow soldering.

● Class 2

- ◆ Temperature Characteristic Code: B (Temperature Characteristics: B, X7R, X5R)

Rated voltage		DC 50 V			DC 25 V			DC 16 V			DC 10 V				
Capacitance (pF)	Capacitance Tolerance	Part No.	Dim. T (mm)	Temp. Char.		Part No.	Dim. T (mm)	Temp. Char.		Part No.	Dim. T (mm)	Temp. Char.			
				B	X7R			B	X7R			B	X7R	X5R	
470	±20 % (M)	ECJTVB1H471M	0.85	○	○										
1000		ECJTVB1H102M	0.85	○	○										
2200		ECJTVB1H222M	0.85	○	○										
4700		ECJTVB1E472M	0.85	○	○										
10000										ECJTVB1C103M	0.85	○	○		
47000														ECJTVB1A473M	0.85
100000													ECJTVB1A104M	0.85	○

Rated voltage		DC 6.3 V		
Capacitance (μF)	Capacitance Tolerance	Part No.	Dim. T (mm)	Temp. Char.
1.0	±20 % (M)	ECJTVB0J105M	0.85	○

Standard packaging quantity of Packaging Style Code *V* (T = 0.85 mm): 4,000 pcs./reel
Avoid flow soldering.

- ◆ Temperature Characteristics Code: F (Temperature Characteristics: F, Y5V)

Rated voltage		DC 16 V			
Capacitance (μF)	Capacitance Tolerance	Part No.	Dim. T (mm)	Temp. Char.	
				F	Y5V
0.1	+80, -20 % (Z)	ECJTVF1C104Z	0.85	○	○

Standard packaging quantity of Packaging Style Code *V* (T = 0.85 mm): 4,000 pcs./reel
Avoid flow soldering.

Standard Products for EIA "1206", Taped Version

● Class 1

- ◆ Temperature Characteristic Code: C (Temperature Characteristics: CH)

Rated voltage		DC 50 V		
Capacitance (pF)	Capacitance Tolerance	Part No.	Dim. T (mm)	Temp. Char. CH
10	±1 pF (F)	ECJRVC1H100F	0.85	○
15	±10 % (K)	ECJRVC1H150K	0.85	○
22		ECJRVC1H220K	0.85	○
33		ECJRVC1H330K	0.85	○
47		ECJRVC1H470K	0.85	○
68		ECJRVC1H680K	0.85	○
100		ECJRVC1H101K	0.85	○
150		ECJRVC1H151K	0.85	○
220		ECJRVC1H221K	0.85	○
330		ECJRVC1H331K	0.85	○
470		ECJRVC1H471K	0.85	○

Standard packaging quantity of Packaging Style Code *V* (T = 0.85 mm): 4,000 pcs./reel
Avoid flow soldering.

● Class 2

- ◆ Temperature Characteristic Code: B (Temperature Characteristics: B, X7R, X5R)

Rated voltage		DC 50 V			DC 16 V			DC 6.3 V				
Capacitance (pF)	Capacitance Tolerance	Part No.	Dim. T (mm)	Temp. Char.		Part No.	Dim. T (mm)	Temp. Char.		Part No.	Dim. T (mm)	Temp. Char. X5R
				B	X7R			B	X7R			
470	±20 % (M)	ECJRVB1H471M	0.85	○	○							
680		ECJRVB1H681M	0.85	○	○							
1000		ECJRVB1H102M	0.85	○	○							
1500		ECJRVB1H152M	0.85	○	○							
2200		ECJRVB1H222M	0.85	○	○							
3300		ECJRVB1H332M	0.85	○	○							
4700		ECJRVB1H472M	0.85	○	○							
6800		ECJRVB1H682M	0.85	○	○							
10000		ECJRVB1H103M	0.85	○	○							
100000						ECJRVB1C104M	0.85	○	○			
1000000									ECJRVB0J105M	0.85	○	

Standard packaging quantity of Packaging Style Code *V* (T = 0.85 mm): 4,000 pcs./reel
Avoid flow soldering.

- ◆ Temperature Characteristic Code: F (Temperature Characteristics: F, Y5V)

Rated voltage		DC 25 V			DC 10 V				
Capacitance (μF)	Capacitance Tolerance	Part No.	Dim. T (mm)	Temp. Char.		Part No.	Dim. T (mm)	Temp. Char.	
				F	Y5V			F	Y5V
0.1	+80, -20 %	ECJRVF1E104Z	0.85	○	○				
1.0	(Z)								

Standard packaging quantity of Packaging Style Code *V* (T = 0.85 mm): 4,000 pcs./reel
Avoid flow soldering.

■ Cross talk characteristics [Ex.]

Size: 0805, Temperature Characteristics: CH, 100 pF

